



WORKHORSE

S P R A Y E R S[®]

by PSE[®], a Division of Green Leaf, Inc.[®]

Assembly / Operation Instructions / Parts

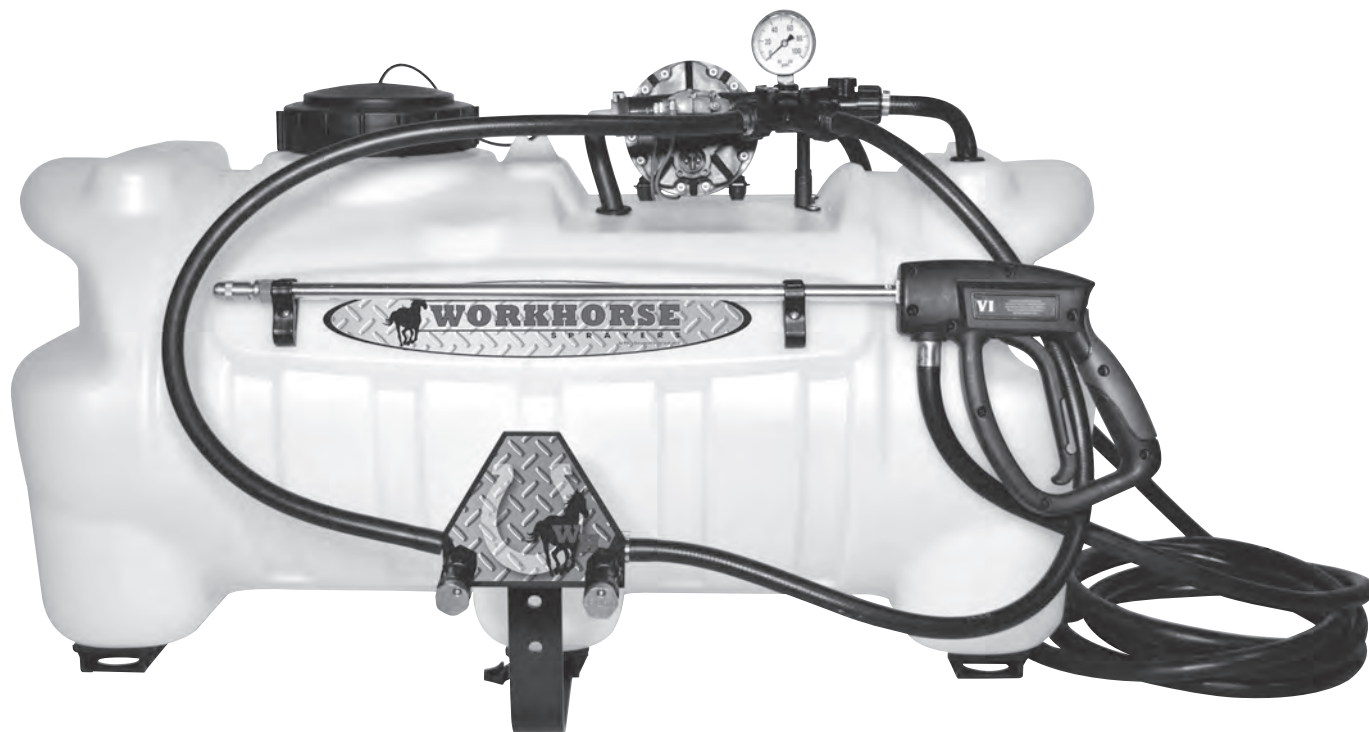

ATV 25BL

DELUXE ATV BOOMLESS SPRAYER

Polyethylene Tank
12 Volt Diaphragm Pump
4.0 G.P.M.
Lever Handgun
15 Ft. of 3/8" Hose (handgun)

Pressure Gauge
Adjustable Pressure range (0-45 PSI Max.)
2 Nozzle Boomless Tips
ATV Mounting Straps
Quick Detach Spray Boom Feature

— GENERAL INFORMATION

The purpose of this manual is to assist you in assembling, operating and maintaining your lawn and garden sprayer. Please read it carefully as it furnishes information which will help you achieve years of dependable trouble-free operation.

— ASSEMBLY

Tools required:

- 1 – 7/16" End Wrench
- 1 – 3/16" Allen Wrench
- 1 – Phillips Screwdriver
- 1 – Thread Sealant

— WARRANTY / PARTS / SERVICE

Products are warranted for 1 year from date of purchase against manufacturer or workmanship defects, with proof of purchase.

Your authorized dealer is the best source of replacement parts and service. To obtain prompt, efficient service, always remember to give the following information:

1. Correct part description and part number.
2. Model number of your sprayer.

Part description and part numbers can be obtained from the illustrated parts list section of this manual.

Whenever you need parts or repair service, contact your distributor / dealer first. For warranty work always take your original sales slip, or other evidence of purchase date, to your distributor / dealer.

— OPERATION

This sprayer is designed to be attached to an ATV rack or other stable surface. The pumping system draws solution from the tank, through the strainer and to the pump. The pump forces the solution under pressure to the spray wand and spray boom. The pump has a pressure switch which will shut the pump off when it reaches 60 PSI. Pressure may be regulated by opening or closing the bypass valve located on the top of the tank. Also, the spray nozzles can independently be cycled on and off with the Y-valve located on the top of the tank. See the illustration in this manual for more details on using the bypass valve.

Regularly inspect the suction supply screen on the inside of the tank. Flush with water to clear any accumulated debris.

— CALIBRATION

Chemical labels may show application rates in gallons per acre. Once you know how much you are going to spray then determine (from the tip chart) the spraying pressure (PSI), and the spraying speed (MPH). Conditions of weather and terrain must be considered when setting the sprayer. Do not spray on windy days. Protective clothing must be worn in some cases. **Be sure to read the chemical label carefully.** Determining the proper speed of the tractor can be done by marking off 100, 200 and 300 feet. The speed chart indicates the number of seconds it takes to travel the distances.

Set the throttle and with a running start travel the distances. Adjust the throttle until you travel the distances in the number of seconds indicated by the speed chart. Once you have reached the throttle setting needed, mark the throttle location so you can stop and go again (returning to the same speed). Add water and proper amount of chemical to tank and drive to the starting place for spraying. When you are ready to spray, turn the boom valve to the "on" position. This will start solution spraying from the tips once the pump is turned on. The pressure will decrease slightly when the boom is spraying.

— BOOMLESS NOZZLE SPRAY INFORMATION

When boom spraying, the recommended boom nozzle height is 24" - 48" above ground level. (Fig. 4) and the pump pressure should be between 14psi and 18psi (See tip chart at the bottom of this page). The manifold has three (3) valves; 2 for left/right spray control on the boom and the other agitates and adjusts pressure. The pressure is adjusted while the sprayer is running. We recommend testing/setting the boom pressure using water. Turn the pump on and open the ¼ turn valve to the boom; then adjust the ¼ turn valve on the bypass/agitation line by opening and/or closing the valve to the desired pressure (your gauge will indicate pressure). Once desired pressure has been set, turn off the valve to the boom and leave the bypass/agitation valve set. It is normal to see a raise in pressure while the pump is returning to the tank which also helps to agitate the tank contents. The pressure is set for the boom; you will also be able to use the wand while the boom is off without adjusting the setting. The pump will run until you shut off the pump with the in-line on/off switch.

— AFTER SPRAYING

After use, fill the sprayer part way with water. Start the sprayer and allow clear water to be pumped through the plumbing system and out through the spray wand and boom. Refill the tank about half full with plain water and use a chemical neutralizer such as Nutra-Sol® or equivalent and repeat cleaning instructions. Flush the entire sprayer with the neutralizing agent. Follow the chemical manufacturer's disposal instructions of all wash or rinsing water.

— WINTER STORAGE

Drain all water and chemical out of sprayer, paying special attention to pump and valves. These items are especially prone to damage from chemicals and freezing weather. The sprayer should be winterized before storage by pumping a solution of RV antifreeze through the entire plumbing. Proper care and maintenance will prolong the life of the sprayer.

— SPEED CHART —

SPEED IN MPH (Miles Per Hour)	Time Required in Seconds to Travel a distance of:		
	100 ft	200 ft	300 ft
1.0	68.0	136	205
2.0	34.0	68	102
3.0	23.0	45	68
4.0	17.0	34	51
5.0	14.0	27	41
6.0	11.0	23	34
7.0	9.7	19	29

1200PS	(1/4" MNPT)			SPEED (MPH)						
	PSI	GPM	SPRAY DISTANCE	1	2	3	4	5	6	7
				GALLONS PER ACRE						
20	1.0	14 ft.	35	18	12	9	7	6	5	
30	1.2	14 ft.	42	21	14	10	8	7	6	
40	1.4	14 ft.	49.5	25	16.5	12	10	8	7	

BOOMINATOR® SPRAY NOZZLES CONVERSION FORMULAS

$$\text{Gallons per 1000 sq. ft} = \frac{\text{GPM} \times 136}{\text{MPH} \times \text{Spray Width in Inches}}$$

$$\text{Gallons per Acre} = \frac{\text{GPM} \times 5940}{\text{MPH} \times \text{Spray Width in Inches}}$$

WARNING: Some chemicals will damage the pump valves if allowed to soak untreated for a long period of time. Always flush the pump with water after use. Do not allow chemicals to sit in pump for extended times of idleness. Follow chemical manufacturers instructions on disposal of all waste water from the sprayer.

Assembly Instructions

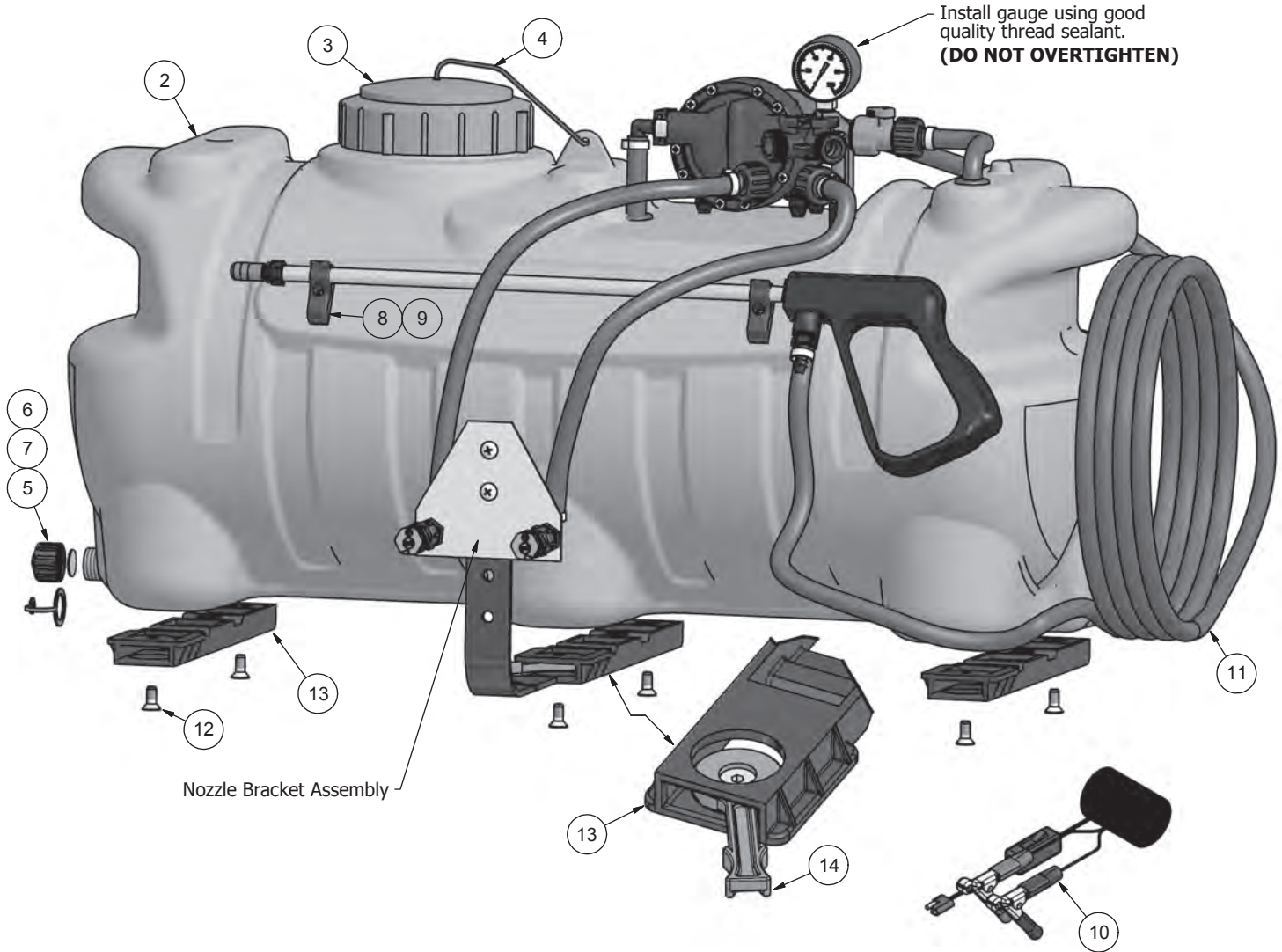

1. Install 3 ATV Mounting Brackets to the bottom of the tank using (6) 5/16-18 x 3/4" screws. (Note that the center mount will include an ATV Helix Lever for securing the nozzle bracket)
2. Install the gauge using a quality thread sealant.
3. Insert the Nozzle bracket assembly into the mounting bracket as illustrated.
4. Attach the Nozzle hoses to the Y-Valve on the top of the tank.
5. Install the tank drain cap and tether.
6. Attach lead wire harness to the pigtail at the rear of the pump. Attach the Red wire to the positive(+) terminal of a 12V battery, and the Black wire to a good ground or the negative terminal(-) of the battery. The Car Light adapter can be used in place of the clips on the wiring harness.

Parts List			
<i>ITEM</i>	<i>QTY</i>	<i>PART NUMBER</i>	<i>DESCRIPTION</i>
1	1	600128	ATV Ratchet Strap (Not Shown)
2	1	600132	25 Gallon Tank
3	1	600133	Tank Lid
4	1	600134	Tank Lid Tether
5	1	600136	Tank Drain Cap
6	1	600137	Tank Drain Cap Tether
7	1	600138	Tank Drain Cap Gasket
8	2	600151	Spray Wand Clip
9	2	600152	Wand Clip Screw
10	1	600153	Lead Wire Assy. w/ Switch (96")
11	1	600156	Spray Wand & Hose Assembly
12	6	600188	5/16-18 x 3/4" FHSCS
13	3	600189	ATV Mounting Bracket
14	1	600190	ATV Helix Lever

Spray Assembly Instructions

Parts List			
ITEM	QTY	PART NUMBER	DESCRIPTION
1	2	600107	1/4-20 Lock Nut
2	2	600116	N1116 P Nut
3	2	600217	Boomless Tip Hose Assembly
4	2	600218	1116A P Adapter Fitting
5	1	600191	ATV Steel Angle Bracket
6	1	600248	Boomless Spray Tip Left
7	1	600249	Boomless Spray Tip Right
8	1	630219	Boomless Tip Mounting Plate
9	2	610017	1/4-20 x 1/2" Pan Head Screw

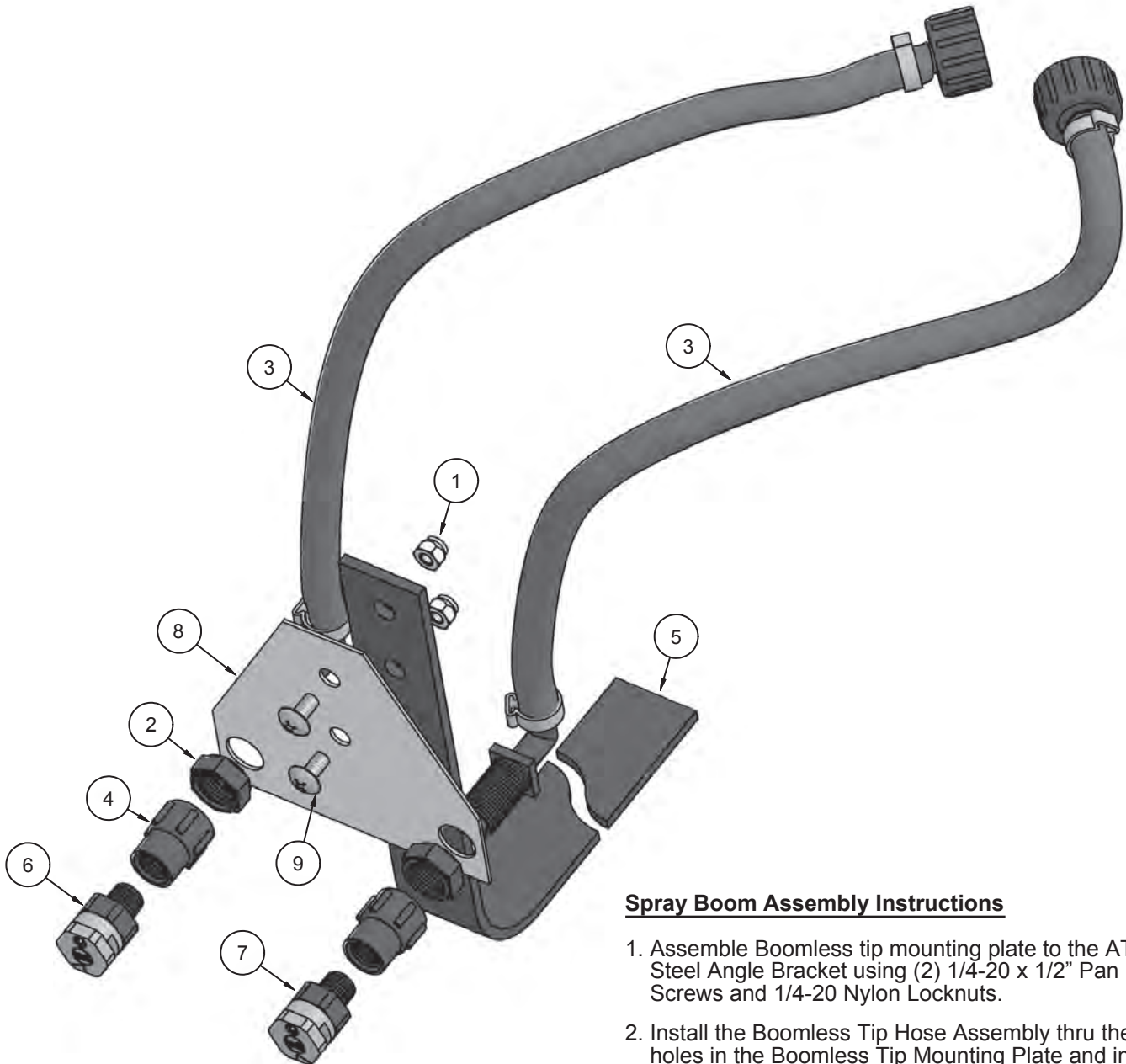
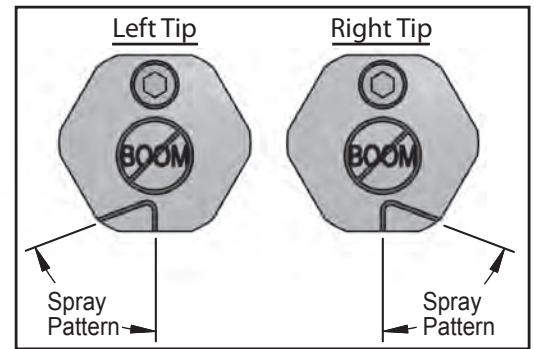

Spray Boom Assembly Instructions

1. Assemble Boomless tip mounting plate to the ATV Steel Angle Bracket using (2) 1/4-20 x 1/2" Pan Head Screws and 1/4-20 Nylon Locknuts.
2. Install the Boomless Tip Hose Assembly thru the holes in the Boomless Tip Mounting Plate and install (2) N1116 P Nuts and 1116A P Adapter fittings.
3. Using a quality thread sealant install the left spray tip in the left adapter and the right tip in the right adapter. (**DO NOT OVERTIGHTEN TIPS**)

Pump & Valve Illustration

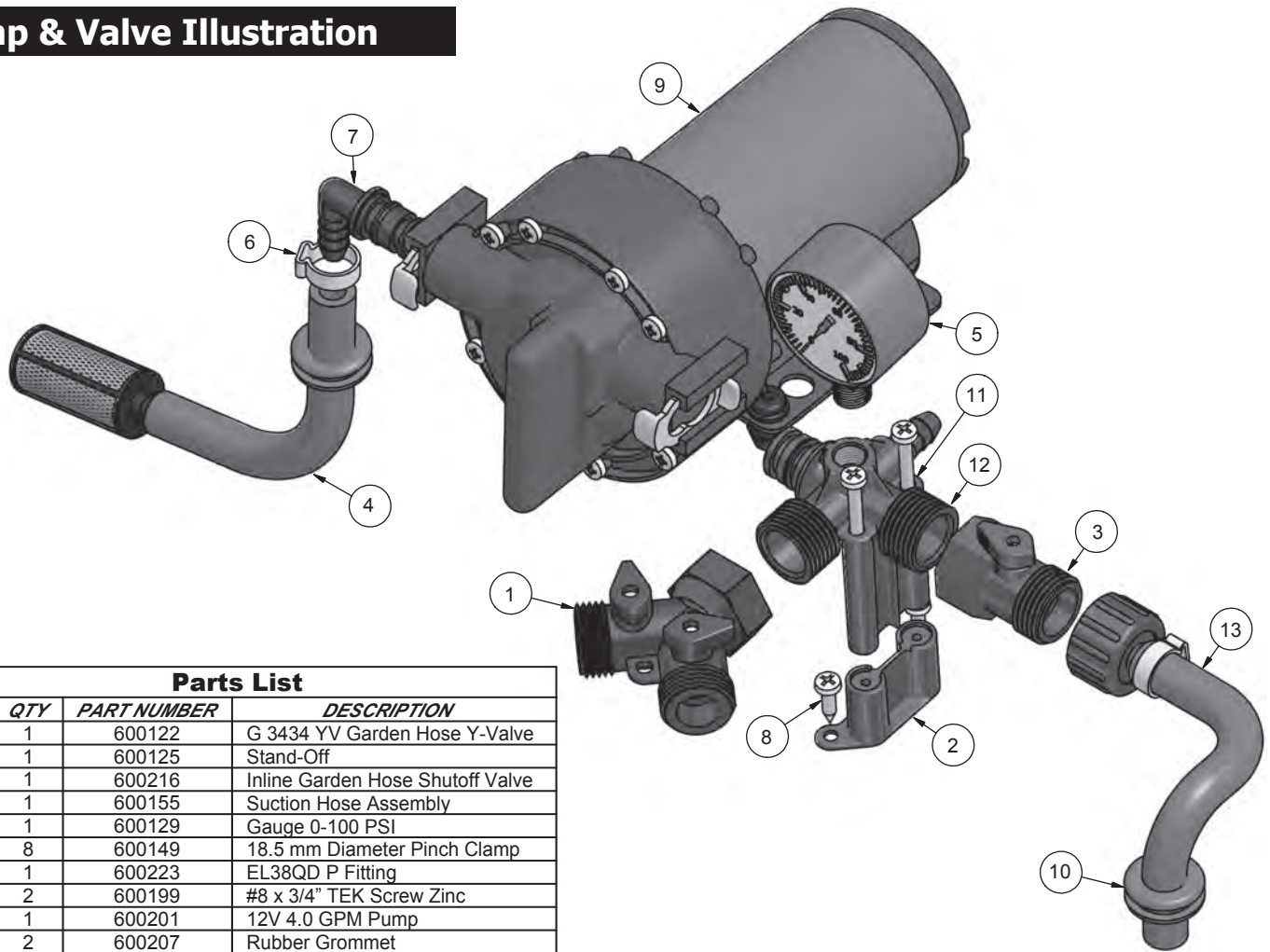

Parts List

ITEM	QTY	PART NUMBER	DESCRIPTION
1	1	600122	G 3434 YV Garden Hose Y-Valve
2	1	600125	Stand-Off
3	1	600216	Inline Garden Hose Shutoff Valve
4	1	600155	Suction Hose Assembly
5	1	600129	Gauge 0-100 PSI
6	8	600149	18.5 mm Diameter Pinch Clamp
7	1	600223	EL38QD P Fitting
8	2	600199	#8 x 3/4" TEK Screw Zinc
9	1	600201	12V 4.0 GPM Pump
10	2	600207	Rubber Grommet
11	2	600210	#10 x 3" Pan Head Tapping Screw
12	1	600212	Cross QD Fitting
13	1	600213	Relief Hose Assembly

Valve Operation

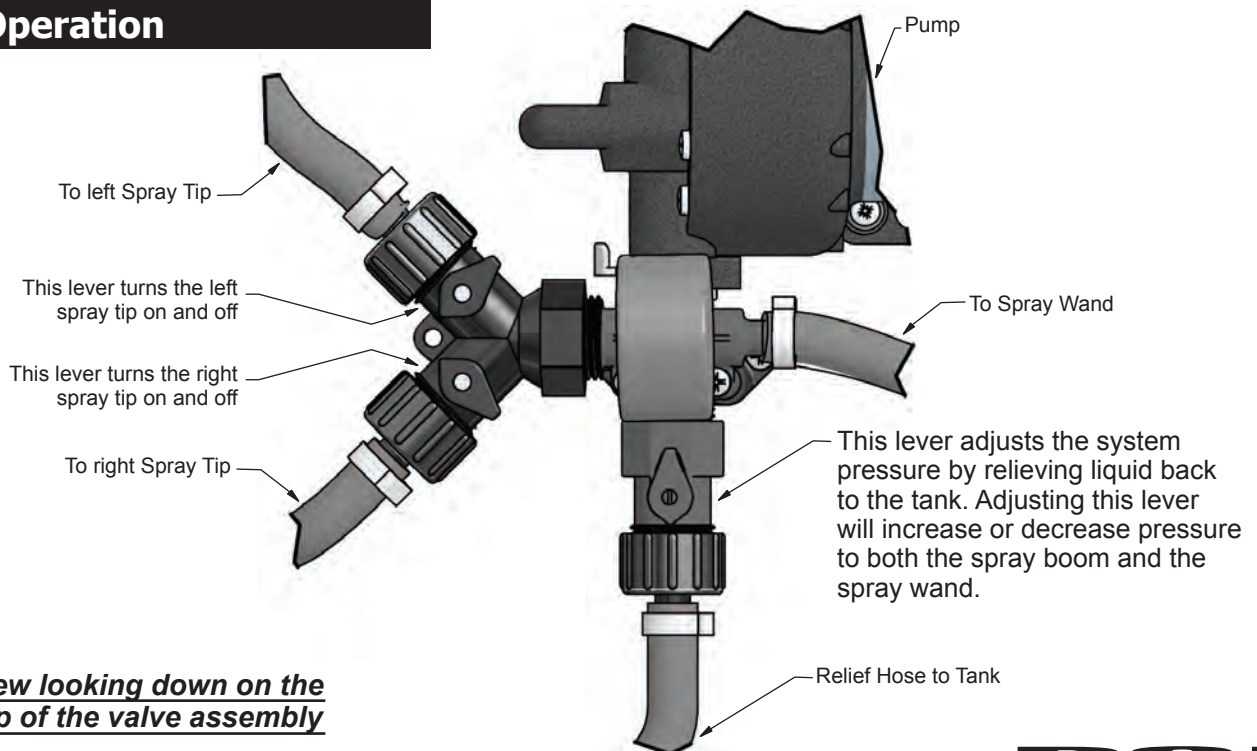

PowerFLO™ 5900 Series

12 Volt DC Motor-Driven Diaphragm Pumps



Model: 5900: 4.0 GPM

Specifications —

Motor:

Type: 12 VDC, permanent magnet, totally enclosed, non-ventilated
Leads: 14 AWG, 12" long
Duty Cycle: See Heat Rise graph
Temperature Limits: Motor is not equipped with thermal protection. For user safety, optimal performance, and maximum motor life, the motor surface temperature should not exceed 180°F (82°C) (see Heat Rise graph above right).

Pump:

Type: 5 chamber positive displacement diaphragm pump, self priming, capable of being run dry, demand or bypass mode.
Certifications: NSF Standard 58
Liquid Temperature: 140°F (60°C) Max.
Priming Capabilities: 14 feet (4 m)
Max Pressure: 60 PSI
Inlet/Outlet Ports: 5900: Quick Attach

Materials of Construction:

Housing: Polypropylene Diaphragm: Santoprene
Valves: Viton Fasteners:
Stainless steel & Zinc plated

Weight: 6 lbs (2.7 kg)

Recommendations —

Electrical:

1. The 5900 series pumps are designed for intermittent duty. Make sure that "OFF" periods are sufficient. Refer to Rapid ON/OFF Operation. Consult the factory for particular data and design criteria.
2. Be sure power supply used is adequate for the application.
3. Pump and motor specifications are based on an alternator charged battery (13.7 VDC)
4. Use sufficient battery supply power. Smaller ATV and lawn tractor batteries may affect pump performance due to low voltage and amp ratings.

* Important return safety instructions:

When you return your pump for warranty or repair, you must always do the following:

1. Flush chemical residue from the pump (best done in the field).
2. Tag pump with type of chemicals having been sprayed.
3. Include complete description of operation problem, such as how pump was used, symptoms of malfunction, etc.

Since pumps can contain residues of toxic chemicals these steps are necessary to protect all the people who handle return shipments, and to help pinpoint the reason for the breakdown.

Operation Precautions —

1. The pump is equipped with a pressure sensing demand switch that controls the maximum operating pressure.
2. Do not operate pump in an explosive environment. Arcing from the motor brushes, switch or excessive heat from an improperly cycled motor may cause an explosion.
3. Do not locate the pump motor near low temperature plastics or combustible material. The surface temperature of the motor may exceed 250°F (120°C).
4. Do not pump gasoline or other flammable liquids. Pump head materials are designed for use with water only. Do not use with petroleum products.
5. Do not assume fluid compatibility. If the fluid is improperly matched to the pumps' elastomers, a leak may occur.
6. To prevent electrical shock, disconnect power before initiating any work. In the case of pump failure, the motor housing and/or pump fluid may carry high voltage to components normally considered safe. Therefore, always consider electrical shock hazard when working with and handling electrical equipment. If uncertain, consult an electrician. Electrical wiring should only be done by a qualified electrician per local and state electrical codes.

Troubleshooting Guide —

Problem/Causes and Remedies:

Pump will not Start

Check:

- Correct voltage ($\pm 10\%$) and electrical connections
- Fuse or breaker
- Pressure switch operation and correct voltage at switch
- Rectifier or motor for open or grounded circuit
- Locked drive assembly

Pump will not Prime (No discharge with motor running)

Check:

- Debris in strainer
- Restriction (kinks) in inlet/outlet tubes
- Debris or swelling in inlet/outlet valves

Pump will not Shut Off (Output line closed and no leaks)

Check:

- Air trapped in outlet line or pump head
- Correct voltage to pump
- Debris in pump inlet/outlet valves
- Loose drive assembly or pump head screws
- Pressure switch operations/adjustments

Leaks from Pump Head or Switch

Check:

- Loose screws at switch or pump head
- Switch diaphragm ruptured or pinched
- Punctured diaphragm if fluid is present

Spray & Pump FAQs —

--Why does the pump not run all the time?

This is a demand pump and only runs with flow; spray wand, by-pass, spray tips or leak in system

--Why does the pump surge while using the spray wand?

Low flow may cause the pump to surge (or cycle). This could happen when the spray wand is adjusted for a small or fine spray pattern. To overcome, slightly open the by-pass valve.

--How do I adjust the pressure?

Pressure should be adjusted by regulating the by-pass valve (slightly opening or closing).

--What is the optimal operating pressure?

40 PSI - This can be accomplished by turning on the pump and adjusting the bypass valve until the gauge reads 40 PSI (or slightly higher). The pump will run continuously. Ensure that the boom and/or handgun is not spraying while you set the pressure. The pressure will drop slightly when the boom and/or handgun is operated.

--What pressure should the pressure gauge read?

Please refer to the operation instructions for boom operating pressures, varying boom pressures can be achieved by regulating or adjusting the by-pass valve. Typically the spray wand will be operated between 20 and 40 PSI.

--What is the recommended PSI to inflate the tires?

30 PSI Max

--My pump quit and will not restart - what should I check?

Check all electrical connections. Ensure switch is in the on position. Check in-line fuse and/or fuse in car adapter end. Ensure correct voltage +/- 10%. 12-13 volt

--Low flow or no flow at all - what should I check?

Check for a clogged suction hose and/or suction strainer. Often you will need to clean the suction strainer. Check for proper voltage.

--Is there a fuse for the sprayer?

Yes, either an in-line fuse, a fuse located in the car adapter housing or both.

--What size fuse should I use as a replacement?

7.5 amp

--What is the range of the spray wand?

35 feet max

--How should I clean the tank after use?

Tank should be cleaned with Nutrasol® or similar tank cleaning agent, and then rinsed with water.

--Is there an adjustment screw on the pump to adjust pressure?

Yes, please refer to the operation instructions, "Adjusting the Pressure Switch".

--How do I remove / replace fuse?

Unscrew in-line fuse connector, or unscrew the car adapter housing.

--Can the spray tip on the wand be replaced with a different type of tip?

Yes, however your wand comes with a #18 tip which is standard. Brass tips generally produce better spray patterns than plastic.

--Each time I turn on the pump my fuse blows.

1) Excessive voltage 2) Improper adjustment of the pressure switch 3) Damaged wiring harness.

--What is the warranty (time duration) on pump, tank, trailer pieces, and accessories?

1 year as stated in operation instructions.

--Pressure gauge reads 85 -90 psi before shutting off - should pump shut off at 60 psi?

Pump 7802 2.0 GPM comes preset from the factory to shut off at 60 PSI. Should this vary please see, "Adjusting the Pressure Switch" in the operation manual. Turn on pump and hold spray wand open, slowly adjust until the pump shuts off at 60 PSI.

--Pump continues to run and surge when not spraying.

Ensure the by-pass is completely closed and your system has no leaks. Check by-pass hose to ensure no fluid is passing through the valve while in the closed position. If so replace valve.

WARNING - Ensure the wiring harness does not become pinched or damaged in any way. This may damage the pump or cause the wiring harness to overheat, resulting in a melt down or fire.